

# 101

C O P E N H A G E N



## **Le Deux Table Lamp - Sand**

Designed by

Kristian Sofus Hansen &  
Tommy Hyldahl

# Le Deux Table Lamp - Sand

---

## Product Description

'Le Deux' the French word for 'the two' is characterized by two oval lampshades merged into each other. Slightly twisted 45 degrees in two directions, the lampshades casts light in different directions, creating a playful and sculptural light installation. Inspired by 70's design, Le Deux is a reinterpretation of futuristic lighting design into a ceramic table lamp.

Perfect as a statement piece on a side table, console, or bedside, Le Deux provides both ambient and directional light, adding warmth and character to any room.

Made from ceramic, Le Deux emphasizes the natural beauty of its material, highlighting the tactile and textured ceramic surface. As it is a hand glazed nature product, the colours may vary slightly.

## Designer Description

Tommy Hyldahl and Kristian Sofus Hansen intertwine their distinct sensibilities to create designs where storytelling, materiality, and timeless form meet in quiet harmony.

With a background in fashion, Tommy brings an intuitive eye for trends, colors, and textures. His process is one of layering histories, blending details and references from past design periods and reimagining them into something fresh and contemporary. Each collection unfolds as a narrative, evolving from concept to creation, with every element contributing to a greater story.

Kristian, who has lived and studied in Japan, seeks to unite Japanese aesthetics with Danish design, creating a characteristic twist on simplicity itself. His work is defined by the search for subtle, original details that elevate each piece with a unique signature. Drawing inspiration from art and sculpture, his creative process unfolds in new and exciting ways, always striving to craft designs that are both functional and timeless.

Together, they craft design that transcends time, poetic yet practical, expressive yet enduring.



# Le Deux Table Lamp - Sand

---

## Main

SKU	231022	Product Family	Le Deux
Product name	Le Deux Table Lamp - Sand	Color	Sand
Product Type	Table Lamp	Size	Regular
		Unit	Piece

## Logistics

EAN number	4251501408345	Package - CBM	0.020
Package height in cm	22.00	Package - Weight KG	3.000
Package width in cm	22.50	Tariff Code No	9405299090
Package length in cm	39.00	Country of origin	China
		Quantity of Inner Boxes	1

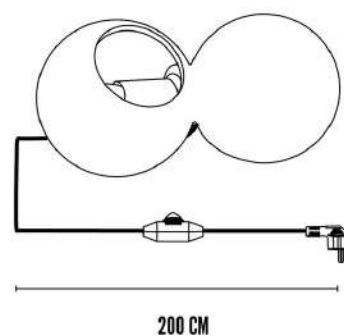
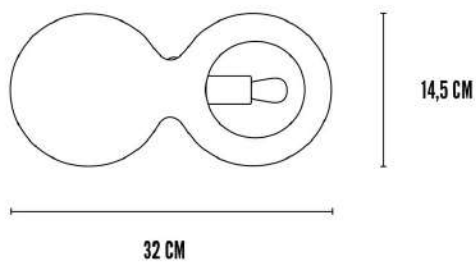

# Le Deux Table Lamp - Sand

---

## Product

Materials	Ceramic	Light Source	E14
Item Height in cm	14.5	Lighting Certification	CE-Certificate
Item width in cm	15	Cable Length	2 m
Item length in cm	32	Max Watt (W)	8
Net weight in kg	2	Socket	E14 x 2 - 230V
Ceiling Cup Size		IP Rating	18

## Led

Color Temperature		Lumen (lm)	N/A
Energy Class	N/A	Illuminant Lifetime (h)	N/A
EPREL No.	N/A	Driver Type	N/A

# Le Deux Table Lamp - Sand

---

## Family Description Text

Le Deux, the French expression for "the two", captures the poetic moment when duality becomes unity. Two oval lampshades seamlessly fused, twist gently away from one another, as if in quiet conversation. Turned 45 degrees in opposite directions, they cast light in a dance of interplay, illuminating space with both balance and tension.

Rooted in the spirit of 1970s design, Le Deux reimagines the era's fascination with the future through the warmth of hand-shaped ceramic. Each lamp celebrates the natural imperfections of its material, tactile, textured, and uniquely alive. Hand-glazed with care, no two are ever quite the same, each one tells its own story of craft, light, and form.

## Color Description

Hand-painted in a soft, golden-beige, this light natural tone carries a sunlit warmth. Reminiscent of coastal dunes and bright shores, it adds an airy calm and effortless neutrality. Brush stroke variations enhance the play of light and shade, giving each piece a one-of-a-kind character.

# Le Deux Table Lamp - Sand

---

## Maintenance Guide Description

Our lamps in hand-painted ceramic are crafted with artisanal detail, where brushstrokes create depth, individuality, and character. To preserve this unique finish, only gentle and minimal care is recommended.

The painted ceramic surface should be cleaned exclusively with a soft, dry microfiber cloth to remove dust. Do not use water, solvents, or cleaning agents, as these may damage the painted surface or alter its texture and colour. Avoid abrasive pads or brushes, Lighting - since they can scratch the finish and disrupt the hand-painted detail.

Always switch off and unplug the lamp before cleaning and keep it away from environments with high humidity or direct water contact. Over time, subtle variations in tone may appear naturally, adding to the authenticity and individuality of each piece.

With simple, careful care, the hand-painted ceramic will retain its expressive character and artisanal beauty, ensuring the lamp remains timeless and unique for years to come.

## Materials Description

Ceramic is one of the oldest and most enduring materials, celebrated for its strength, versatility, and timeless beauty. Shaped from natural clay and fired at high temperatures, it achieves a density and durability that make it ideal for both functional and decorative use. Its smooth surface provides the perfect canvas for craftsmanship.

Our ceramic is elevated through hand painting, where layers of pigment are carefully applied by skilled artisans. This process creates subtle variations in tone, texture, and detail, ensuring that no two pieces are ever alike. The result is a material that combines resilience with individuality practical enough for everyday use, yet refined enough to stand as an object of art.

Hand-painted ceramic embodies the harmony of nature, craft, and time: a surface that carries both the permanence of fired clay and the soulful presence of the human hand.