

101

C O P E N H A G E N



AD Floor Lamp - Oxidized

Designed by

Kristian Sofus Hansen &
Tommy Hyldahl

AD Floor Lamp - Oxidized

Product Description

The round, geometric shape and sculptural construction of the AD Floor Lamp is influenced by the austere Brutalist movement of the mid-20th Century.

The oxidized surface is textured and almost resembling concrete as a nod to the architectural source of inspiration. Thin aluminum plates comprising the plate geometry shape enclose the light source providing a smooth light scattering, the lamp is pleasant yet functional in every setting. It looks paper thin from some angles and solid from others playing with the subtle movement of light.

Designer Description

Tommy Hyldahl and Kristian Sofus Hansen intertwine their distinct sensibilities to create designs where storytelling, materiality, and timeless form meet in quiet harmony.

With a background in fashion, Tommy brings an intuitive eye for trends, colors, and textures. His process is one of layering histories, blending details and references from past design periods and reimagining them into something fresh and contemporary. Each collection unfolds as a narrative, evolving from concept to creation, with every element contributing to a greater story.

Kristian, who has lived and studied in Japan, seeks to unite Japanese aesthetics with Danish design, creating a characteristic twist on simplicity itself. His work is defined by the search for subtle, original details that elevate each piece with a unique signature. Drawing inspiration from art and sculpture, his creative process unfolds in new and exciting ways, always striving to craft designs that are both functional and timeless.

Together, they craft design that transcends time, poetic yet practical, expressive yet enduring.



AD Floor Lamp - Oxidized

Main

SKU	111107	Product Family	AD
Product name	AD Floor Lamp - Oxidized	Color	Oxidized
Product Type	Floor Lamp	Size	Regular
		Unit	Piece

Logistics

EAN number	4251501403203	Package - CBM	0.121
Package height in cm	23.00	Package - Weight KG	4.100
Package width in cm	70.00	Tariff Code No	9405299090
Package length in cm	75.00	Country of origin	China
		Quantity of Inner Boxes	1

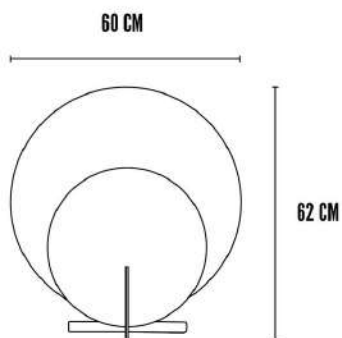

AD Floor Lamp - Oxidized

Product

Materials	Oxidized Aluminum	Light Source	E27
Item Height in cm	62	Lighting Certification	CE-Certificate
Item width in cm	12	Cable Length	2 m
Item length in cm	60	Max Watt (W)	8
Net weight in kg	4	Socket	E27 x 1 - 230V
Ceiling Cup Size		IP Rating	20

Led

Color Temperature		Lumen (lm)	N/A
Energy Class	N/A	Illuminant Lifetime (h)	N/A
EPREL No.	N/A	Driver Type	N/A

AD Floor Lamp - Oxidized

Family Description Text

The round, geometric form and sculptural presence of the AD Floor Lamp draw inspiration from the austere beauty of mid-20th century Brutalism. Thin aluminium plates, arranged in a precise architectural rhythm, embrace the light source and transform it into a soft, diffused glow. The result is illumination that feels both functional and quietly elegant.

From one angle the lamp appears almost weightless, as if paper-thin. From another it reveals a grounded solidity, shifting with the play of shadow and reflection. In this dialogue between lightness and strength, the AD Floor Lamp becomes more than illumination, it is a sculptural statement of form, light, and atmosphere.

Color Description

Oxidized Aluminium is defined by a raw, industrial character. Through an intense chemical treatment, the surface develops irregular markings that make each piece unique. The finish resembles architectural concrete tactile, dramatic, and alive with texture.

AD Floor Lamp - Oxidized

Maintenance Guide Description

Our lamps finished in oxidized aluminium are crafted to highlight the natural depth and variation of the surface, giving each piece a unique and timeless character. To preserve their beauty, careful and minimal maintenance is essential.

The oxidized surface should be cleaned only with a soft, dry microfiber cloth to remove dust. Do not use water, as moisture may react with the oxidized finish and alter its appearance. Avoid abrasive pads, harsh detergents, solvents, or metal polishes since these can strip away or damage the oxidized layer.

Because the oxidized effect is a living finish, subtle changes in tone and texture may occur naturally over time. This patina is part of the material's character and should be embraced as a sign of its authenticity.

Always switch off and unplug the lamp before cleaning and avoid placing it in areas with high humidity or direct water exposure. With simple, gentle care, the oxidized aluminium will retain its refined depth and natural patina, ensuring the lamp remains expressive and enduring for years to come.

Materials Description

Oxidized aluminium is created through a brief but intense acid bath that transforms the surface into something raw and tactile. Each piece emerges with irregular markings, scars of creation that can never be repeated. The result is a surface that feels industrial and expressive, reminiscent of architectural concrete stark, dramatic, and alive with texture.