

# 101

C O P E N H A G E N



## **Clam Table Lamp - Burned Black**

Designed by

Kristian Sofus Hansen &  
Tommy Hyldahl

# Clam Table Lamp - Burned Black

---

## Product Description

The Clam Table Lamp is a tribute to the harmony of simplicity and the artistry of light. The table lamp, with its two gracefully opposing shades, orchestrates a mesmerizing balance of direct and indirect illumination, while the wall lamp, with its singular shade, casts a poetic and atmospheric glow.

Inspired by the serene aesthetics of Japanese design, each lamp embodies a quiet elegance, where light gently reflects off delicately curved metal screens, infusing the space with warmth and tranquility.

Perfect as a bedside or desk lamp, the Clam Table Lamp provides both functional light for reading and a soft, ambient glow for creating atmosphere. Its sculptural form makes it equally suited for living rooms, sideboards, or console tables, where it doubles as both a lighting source and a decorative statement.

Meticulously crafted, the wall lamp in burned blacked metal ensures a seamless complement to any interior. Hand-brushed with precision, every plated metal body exudes artisanal sophistication, a true testament to the masterful craftsmanship that defines the Clam Series.

## Designer Description

Tommy Hyldahl and Kristian Sofus Hansen intertwine their distinct sensibilities to create designs where storytelling, materiality, and timeless form meet in quiet harmony.

With a background in fashion, Tommy brings an intuitive eye for trends, colors, and textures. His process is one of layering histories, blending details and references from past design periods and reimagining them into something fresh and contemporary. Each collection unfolds as a narrative, evolving from concept to creation, with every element contributing to a greater story.

Kristian, who has lived and studied in Japan, seeks to unite Japanese aesthetics with Danish design, creating a characteristic twist on simplicity itself. His work is defined by the search for subtle, original details that elevate each piece with a unique signature. Drawing inspiration from art and sculpture, his creative process unfolds in new and exciting ways, always striving to craft designs that are both functional and timeless.

Together, they craft design that transcends time, poetic yet practical, expressive yet enduring.



# Clam Table Lamp - Burned Black

---

## Main

SKU	110048	Product Family	Clam
Product name	Clam Table Lamp - Burned Black	Color	Burned Black
Product Type	Table Lamp	Size	Regular
		Unit	Piece

## Logistics

EAN number	4251501404446	Package - CBM	0.076
Package height in cm	31.00	Package - Weight KG	5.700
Package width in cm	46.00	Tariff Code No	9405299090
Package length in cm	53.00	Country of origin	China
		Quantity of Inner Boxes	1

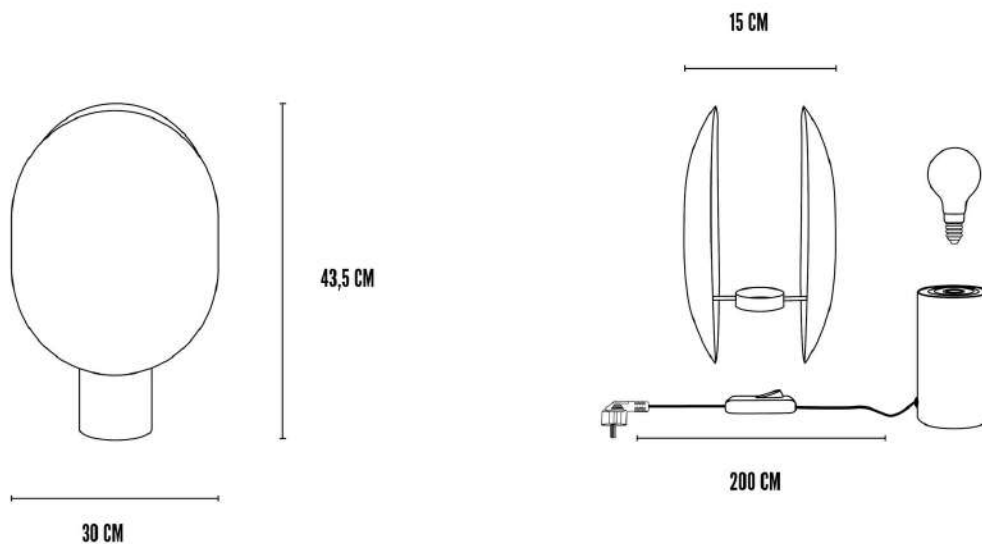

# Clam Table Lamp - Burned Black

---

## Product

Materials	Powder Coated Aluminium	Light Source	E14
Item Height in cm	43.5	Lighting Certification	CE-Certificate
Item width in cm	15	Cable Length	2 m
Item length in cm	30	Max Watt (W)	8
Net weight in kg	4.1	Socket	E14 x 1 - 230V
Ceiling Cup Size		IP Rating	20

## Led

Color Temperature		Lumen (lm)	N/A
Energy Class	N/A	Illuminant Lifetime (h)	N/A
EPREL No.	N/A	Driver Type	N/A

# Clam Table Lamp - Burned Black

---

## Family Description Text

The Clam Series is a tribute to the harmony of simplicity and the poetry of light. The table lamp, with its two gracefully opposing shades, composes a delicate balance of direct and indirect illumination. The wall lamp, with its singular curved shade, offers a softer glow, atmospheric and serene.

Inspired by the quiet beauty of Japanese design, each lamp carries an understated elegance, as light gently reflects across curved aluminium screens, infusing the room with warmth and tranquillity. Every line, every surface, speaks of meticulous attention, a testament to the craftsmanship that gives the Clam Series its timeless presence.

## Color Description

Burned Black is a deep, charcoal-black tone enriched with a subtle warm red undercurrent. Its matte powder-coated surface delivers a smooth, consistent appearance, while gentle tonal shifts emerge as light moves across it. Bold yet quietly warm, Burned Black brings depth, richness, and a refined architectural presence to any palette.

# Clam Table Lamp - Burned Black

---

## Maintenance Guide Description

Our lights crafted in powder coated aluminium are designed to offer lasting durability and a refined, contemporary finish. To preserve their beauty and ensure long-lasting performance, regular and gentle care is essential. The powder coated aluminium should be dusted regularly with a soft, dry microfiber cloth, and for deeper cleaning, a slightly damp cloth with mild, pH-neutral soap may be used, wiping gently to avoid compromising the coating. Avoid abrasive pads, acidic or alkaline solutions, solvents, or metal polishes, as these can dull, scratch, or damage the surface. Always switch off and unplug the light before cleaning, and prevent exposure to excessive humidity or direct water contact to protect both the coating and the internal electrical components. With simple, consistent care, the powder coated aluminium will maintain its elegant finish, ensuring your light remains beautiful and timeless for years to come.

## Materials Description

Powder-coated aluminium reflects the balance of strength and refinement. Each piece is coated with precision, resulting in a smooth and uniform surface that emphasizes form and silhouette with clarity. The finish enhances durability while introducing a calm, tactile character that enriches the material's expression.