

101

C O P E N H A G E N



Clam Table Lamp - Brass

Designed by

Kristian Sofus Hansen &
Tommy Hyldahl

Clam Table Lamp - Brass

Product Description

The Clam Table Lamp is a tribute to the harmony of simplicity and the artistry of light. The table lamp, with its two gracefully opposing shades, orchestrates a mesmerizing balance of direct and indirect illumination, while the wall lamp, with its singular shade, casts a poetic and atmospheric glow.

Inspired by the serene aesthetics of Japanese design, each lamp embodies a quiet elegance, where light gently reflects off delicately curved metal screens, infusing the space with warmth and tranquility.

Perfect as a bedside or desk lamp, the Clam Table Lamp provides both functional light for reading and a soft, ambient glow for creating atmosphere. Its sculptural form makes it equally suited for living rooms, sideboards, or console tables, where it doubles as both a lighting source and a decorative statement.

Meticulously crafted, the wall lamp in plated brass ensures a seamless complement to any interior. Hand-brushed with precision, every plated metal body exudes artisanal sophistication, a true testament to the masterful craftsmanship that defines the Clam Series.

Designer Description

Tommy Hyldahl and Kristian Sofus Hansen intertwine their distinct sensibilities to create designs where storytelling, materiality, and timeless form meet in quiet harmony.

With a background in fashion, Tommy brings an intuitive eye for trends, colors, and textures. His process is one of layering histories, blending details and references from past design periods and reimagining them into something fresh and contemporary. Each collection unfolds as a narrative, evolving from concept to creation, with every element contributing to a greater story.

Kristian, who has lived and studied in Japan, seeks to unite Japanese aesthetics with Danish design, creating a characteristic twist on simplicity itself. His work is defined by the search for subtle, original details that elevate each piece with a unique signature. Drawing inspiration from art and sculpture, his creative process unfolds in new and exciting ways, always striving to craft designs that are both functional and timeless.

Together, they craft design that transcends time, poetic yet practical, expressive yet enduring.



Clam Table Lamp - Brass

Main

SKU	110046	Product Family	Clam
Product name	Clam Table Lamp - Brass	Color	Brass
Product Type	Table Lamp	Size	Regular
		Unit	Piece

Logistics

EAN number	4251501400578	Package - CBM	0.076
Package height in cm	31.00	Package - Weight KG	5.700
Package width in cm	46.00	Tariff Code No	9405299090
Package length in cm	53.00	Country of origin	China
		Quantity of Inner Boxes	1

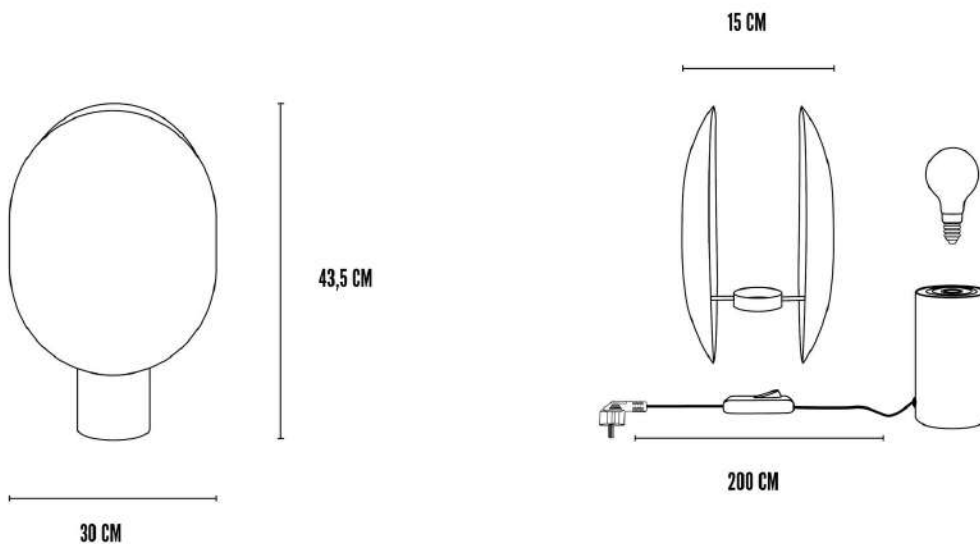

Clam Table Lamp - Brass

Product

Materials	Hand Brushed Plated Aluminium	Light Source	E14
Item Height in cm	43.5	Lighting Certification	CE-Certificate
Item width in cm	15	Cable Length	2 m
Item length in cm	30	Max Watt (W)	8
Net weight in kg	4.1	Socket	E14 x 1 - 230V
Ceiling Cup Size		IP Rating	20

Led

Color Temperature		Lumen (lm)	N/A
Energy Class	N/A	Illuminant Lifetime (h)	N/A
EPREL No.	N/A	Driver Type	N/A

Clam Table Lamp - Brass

Family Description Text

The Clam Series is a tribute to the harmony of simplicity and the poetry of light. The table lamp, with its two gracefully opposing shades, composes a delicate balance of direct and indirect illumination. The wall lamp, with its singular curved shade, offers a softer glow, atmospheric and serene.

Inspired by the quiet beauty of Japanese design, each lamp carries an understated elegance, as light gently reflects across curved aluminium screens, infusing the room with warmth and tranquillity. Every line, every surface, speaks of meticulous attention, a testament to the craftsmanship that gives the Clam Series its timeless presence.

Color Description

Hand Brushed Brass has a golden metallic tone that resembles gold but with a softer, more muted character. Fine brushstrokes create a silky matte surface, reducing shine and adding depth and movement. The result is a warm, elegant finish that feels both timeless and contemporary.

Clam Table Lamp - Brass

Maintenance Guide Description

Hand-brushed plated aluminium is sealed with a protective matte coating that preserves its soft sheen and quiet variations in texture. To maintain the beauty of your light, simply dust or wipe the surface with a soft cloth, using a little water only when necessary and always drying immediately afterwards. Abrasive cloths, brushes, solvents or strong detergents should be avoided, as they may damage the delicate brushed finish and its protective layer. The subtle variations in tone are intentional, a natural result of the hand-brushing process, and are not meant to be polished away. Always switch off and unplug the lamp before cleaning, and avoid exposing it to excessive humidity or direct contact with water. With gentle care, the surface will retain its richness and timeless character, carrying the traces of craftsmanship that make each piece unique.

Materials Description

Hand-brushed plated aluminium reflects the meeting of craftsmanship and time. Each piece is plated and then brushed by hand, creating subtle variations in tone and texture that make every object unique. A final matte coating softens the sheen into a silky finish, enhancing the surface with quiet movement and depth.