

# 101

C O P E N H A G E N



## **Snake Wall Lamp - Brass**

Designed by

Kristian Sofus Hansen &  
Tommy Hyldahl

# Snake Wall Lamp - Brass

---

## Product Description

The Snake Wall Lamp is a study in movement, an exploration of how light can flow like a living line through space. Inspired by the silent grace of a snake in motion, the design transforms solid metal into a gesture of softness, where curves and bends become expressions of quiet energy.

The form appears to move even when still. Slender pipes twist with sculptural precision, leading the eye toward a refined conic shade that emits a warm, inviting glow. Light diffuses gently, creating an atmosphere that contrasts beautifully with the cool tactility of metal, balancing structure and fluidity in a calm yet expressive presence.

In Hand Brushed Brass, the lamp takes on a warm, golden character. Fine brushstrokes soften the metallic surface, reducing shine and adding depth and movement. The result is a timeless finish that feels both contemporary and quietly luxurious, bringing warmth and elegance to the sculptural form.

The Snake Wall Lamp is ideal as accent lighting in living rooms, bedrooms, or hallways, where its sculptural profile can be appreciated up close. Its vertical expression makes it perfect beside a sofa, above a bedside table, or as a pair framing a mirror or artwork, adding both atmosphere and architectural character to the space.

## Designer Description

Tommy Hyldahl and Kristian Sofus Hansen intertwine their distinct sensibilities to create designs where storytelling, materiality, and timeless form meet in quiet harmony.

With a background in fashion, Tommy brings an intuitive eye for trends, colors, and textures. His process is one of layering histories, blending details and references from past design periods and reimagining them into something fresh and contemporary. Each collection unfolds as a narrative, evolving from concept to creation, with every element contributing to a greater story.

Kristian, who has lived and studied in Japan, seeks to unite Japanese aesthetics with Danish design, creating a characteristic twist on simplicity itself. His work is defined by the search for subtle, original details that elevate each piece with a unique signature. Drawing inspiration from art and sculpture, his creative process unfolds in new and exciting ways, always striving to craft designs that are both functional and timeless.

Together, they craft design that transcends time, poetic yet practical, expressive yet enduring.



# Snake Wall Lamp - Brass

---

## Main

SKU	262023	Product Family	Snake
Product name	Snake Wall Lamp - Brass	Color	Brass
Product Type	Wall Lamp	Size	Regular
		Unit	Piece

## Logistics

EAN number	4251501415084	Package - CBM	0.005
Package height in cm	44.00	Package - Weight KG	4.500
Package width in cm	10.00	Tariff Code No	9405199090
Package length in cm	12.00	Country of origin	China
		Quantity of Inner Boxes	4

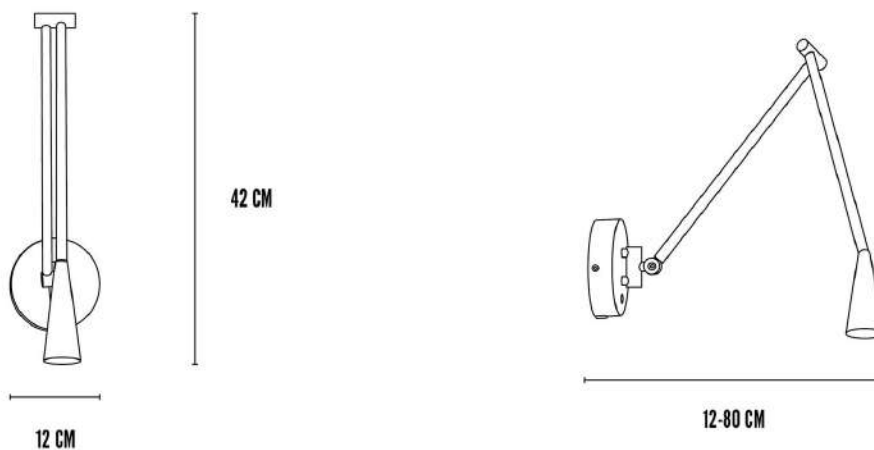

# Snake Wall Lamp - Brass

---

## Product

Materials	Hand Brushed Plated Aluminium	Light Source	G9
Item Height in cm	42	Lighting Certification	CE-Certificate
Item width in cm	12	Cable Length	None
Item length in cm	12	Max Watt (W)	8
Net weight in kg	3	Socket	G9 x 1 - 230V
Ceiling Cup Size	N/A	IP Rating	20

## Led

Color Temperature		Lumen (lm)	N/A
Energy Class	N/A	Illuminant Lifetime (h)	N/A
EPREL No.	N/A	Driver Type	N/A

## Snake Wall Lamp - Brass

---

### Family Description Text

The Snake Collection is a study in movement, an exploration of how light can flow like a living line through space. Inspired by the silent grace of a snake in motion, each piece transforms solid metal into a gesture of softness, where curves and bends become expressions of quiet energy.

The form seems to move even when still. Slender pipes bend and twist with sculptural precision, leading the eye toward refined conic shades that emit a warm, inviting glow. The light diffuses gently, creating an atmosphere that contrasts beautifully with the cool tactility of metal. This balance between hardness and warmth, structure and fluidity, defines the collection's calm yet expressive presence.

Designed to shape both space and mood, the Snake Collection invites light to become part of the architecture, not merely an object but a motion captured in form. Each curve tells a story of transformation, where material becomes movement and illumination becomes emotion. The result is a timeless expression of modern elegance, simple, poised, and quietly alive.

### Color Description

Hand Brushed Brass has a golden metallic tone that resembles gold but with a softer, more muted character. Fine brushstrokes create a silky matte surface, reducing shine and adding depth and movement. The result is a warm, elegant finish that feels both timeless and contemporary.

## Snake Wall Lamp - Brass

---

### Maintenance Guide Description

Hand-brushed plated aluminium is sealed with a protective matte coating that preserves its soft sheen and quiet variations in texture. To maintain the beauty of your light, simply dust or wipe the surface with a soft cloth, using a little water only when necessary and always drying immediately afterwards. Abrasive cloths, brushes, solvents or strong detergents should be avoided, as they may damage the delicate brushed finish and its protective layer. The subtle variations in tone are intentional, a natural result of the hand-brushing process, and are not meant to be polished away. Always switch off and unplug the lamp before cleaning, and avoid exposing it to excessive humidity or direct contact with water. With gentle care, the surface will retain its richness and timeless character, carrying the traces of craftsmanship that make each piece unique.

### Materials Description

Hand-brushed plated aluminium reflects the meeting of craftsmanship and time. Each piece is plated and then brushed by hand, creating subtle variations in tone and texture that make every object unique. A final matte coating softens the sheen into a silky finish, enhancing the surface with quiet movement and depth.